

## WHY ARE THE MADHIL BLOCKS SO SPECIAL?

Because it allows flexibility and speed that cast in place walls cannot compete with. No mortar needed, thanks to the block's design, you can create a stable, adaptable stacking system with endless expansion possibilities. Ideal for temporary and permanent building works. Even non technical customers can easily build Madhil Block walls.

**MADHIL BLOCKS** are the most simple and effective method as permanent fencing or compound walls. Traffic police, municipalities and governments can use our blocks as a border between traffic and pedestrian zones to offer citizens a feeling of safety when walking besides a busy road. With a weight of 1000 kg per block they can be used as "No Entry" zone. Besides that it is fastest way to create and alter a demarcation in a very short period of time.

### APPLICATIONS:

- Temporary walls
- Permanent outer walls of factories, warehouses and sheds
- Material storage bays
- Aggregate separation walls in RMC plants and recycling plants
- Retaining walls on highways
- Slope retaining walls in Ghat / Hill roads
- Crash barrier walls
- Security barriers in public places
- Counter weights
- Fencing base wall



No plastering required



Factory Address: No: B269/1, Opp.to ACC Ready Mix Unit,  
before Sidco Industrial Estate, Thiruneermalai Road, Thirumudivakkam,  
Chennai – 600 044.

Head Office: Doxa Business Center, 16, Cenotaph Road, Teynampet,  
Chennai – 600 018. Ph. No: +91 44 66185522  
LLP ID: AAQ-8250 | GSTIN: 33AAVFB5359C1ZD  
UAM No.: TN02A0173372 | PAN: AAVFB5359C  
E mail: info@bomacrete.com | www.bomacrete.com/madhil

# MADHIL™ BLOCKS

*Interlocking Large Modular  
Concrete Blocks*

A Product of



# MADHIL™ BLOCKS

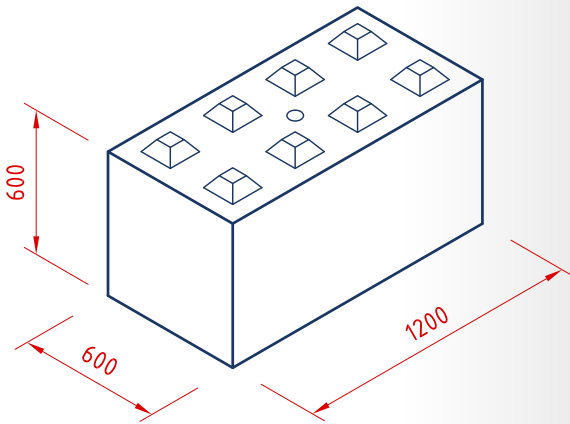

Block Type C Isometric View

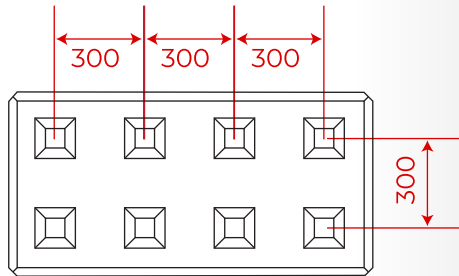

Semi-spherical recess with hook for lifting

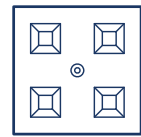

Block Type A

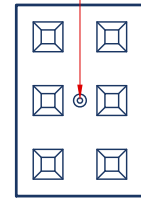

Block Type B

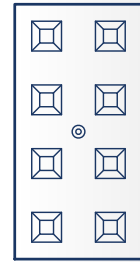

Standard Block Type C



All Block Types End View

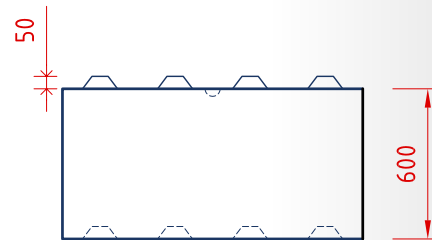

Block Type C Side View

## « CONCRETE INTERLOCKING BLOCKS »

Our blocks offer unparalleled flexibility, easy to install and a reusable construction material. This innovative and low cost design makes construction and deconstruction simple. We are the first to bring this revolutionary concept to India.

Each Standard block (120x60x60) weighs 1000kg and simply locks into place as it is assembled and stands tall as a wall without the need for any cement or mortar or adhesive. No complex foundations are required. Free standing walls up to 5 M height are stable.

Flexibility to use and fit, allows single or double skin walls to be created to fit the specific client needs or environmental regulations. Custom color blocks can be made on special request.

**MADHIL BLOCKS** are highly sustainable as they require no grout to seal them. They are quick and easy to install and decommission for relocation. With high impact resistance, our blocks can be used as crash barriers or blast resistant walls.

### TECHNICAL BENEFITS:

- Factory made product with strict quality control and highly durable concrete mix.
- Has a clean cement appearance.
- No painting, pointing or plastering needed.
- No extensive foundation works needed.
- No ground fastenings needed.
- The assembled block acts like a single mass unit under loading.
- Simple and quick to install.
- No maintenance.
- Can be left outdoors without fear of deterioration or corrosion.
- Can be used as permanent and temporary works.
- Colored block options available to suit environmental needs.
- Blocks can be produced in single or half length options.
- Retaining walls upto 3 M possible without Geo Grids.

**MADHIL BLOCKS** are interlocking concrete blocks,

similar to the famous  play systems.

Weight of standard block = 1000kg